

# MONSTER

## Dimensions

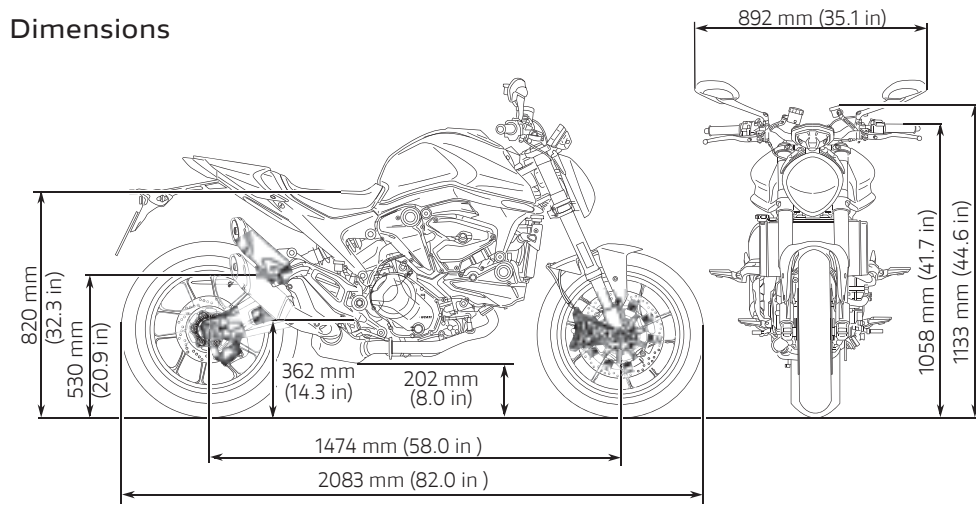

## Power and torque

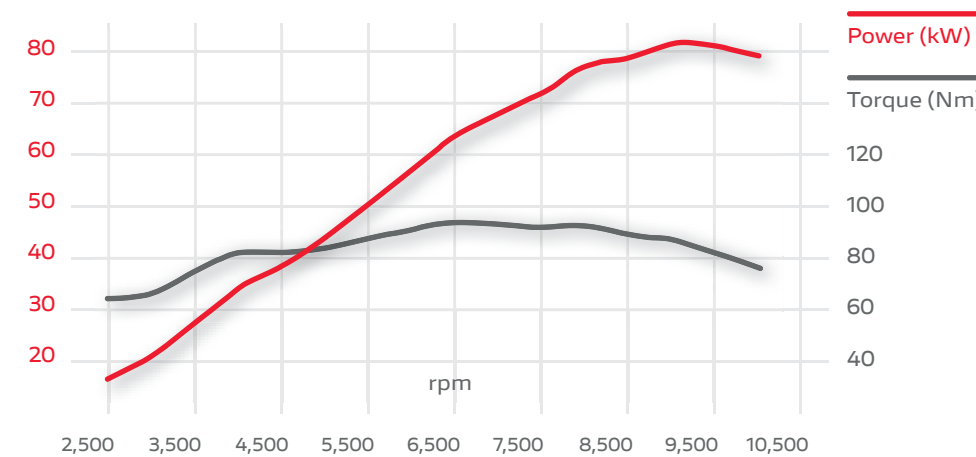

Engine	
<b>Engine</b>	Testatretta 11°, V2 - 90°, 4 valves per cylinder, desmodromic valvetrain, liquid cooled
<b>Displacement</b>	937 cc (57 cu in)
<b>Bore X stroke</b>	94 mm x 67.5 mm
<b>Compression ratio</b>	13.3:1
<b>Power</b>	111 hp (82 kW) @ 9,250 rpm
<b>Torque</b>	9.5 kgm (93 Nm, 69 lb ft) @ 6,500 rpm
<b>Fuel injection</b>	Electronic fuel injection system, Ø 53 mm throttle bodies with Ride-by-Wire system
<b>Exhaust</b>	Pre-muffler and twin muffler, catalytic converter and 2 lambda probes
Transmission	
<b>Gearbox</b>	6 speed
<b>Primary drive</b>	Straight cut gears, ratio 1.85:1
<b>Ratio</b>	1=37/15, 2=30/17, 3=28/20, 4=26/22, 5=24/23, 6=23/24
<b>Final drive</b>	Chain, front sprocket z15, rear sprocket z43
<b>Clutch</b>	Slipper and self-servo multiplate wet clutch with hydraulic control

Chassis	
<b>Frame</b>	Aluminum alloy Front Frame
<b>Front suspension</b>	Ø 43 mm usd fork
<b>Front wheel</b>	Light alloy cast, 3.5" x 17"
<b>Front tyre</b>	Pirelli Diablo Rosso III 120/70 ZR17
<b>Rear Suspension</b>	Progressive linkage, preload adjustable monoshock, aluminium double-sided swingarm
<b>Rear Wheel</b>	Light alloy cast, 5.5" x 17"
<b>Rear tyre</b>	Pirelli Diablo Rosso III 180/55 ZR17
<b>Wheel travel (front/rear)</b>	130 mm / 140 mm (5.1 in / 5.5 in)
<b>Front brake</b>	2 x Ø 320 mm semi-floating discs, radially mounted Brembo M4.32 monobloc 4-piston callipers, radial master cylinder, Cornering ABS
<b>Rear brake</b>	Ø 245 mm disc, Brembo 2-piston floating calliper, Cornering ABS
<b>Instrumentation</b>	4.3" TFT colour display
Dimensions and weights	
<b>Dry weight</b>	166 kg (366 lb)

<b>Kerb weight</b>	188 kg (414 lb)
<b>Seat height</b>	820 mm (32.3 in) 800 mm (31.5 in) (accessory low seat) 775 mm (30.5 in) (accessory low seat + low suspension kit)
<b>Wheelbase</b>	1,474 mm (58.0 in)
<b>Rake</b>	24°
<b>Front wheel trail</b>	93 mm (3.7 in)
<b>Fuel tank capacity</b>	14 l (3.7 US gal)
<b>Number of seats</b>	2
Safety equipment	
Riding Modes, Power Modes, Cornering ABS, Ducati Traction Control, Ducati Wheelie Control, Daytime Running Light**	
Standard equipment	
Ducati Quick Shift, Ducati Power Launch, 4.3" TFT colour display, Full LED headlight and lighting system, Dynamic turn indicators**, USB power socket, Flyscreen (Plus version), Passenger seat cover (Plus version)	
Ready for	
Ducati Multimedia System, Heated grips	

Warranty	
<b>Warranty</b>	24 months, unlimited mileage
Maintenance	
<b>Oil change</b>	15,000 km (9,000 miles) / 24 months
<b>Valve clearance check</b>	30,000 km (18,000 miles)
Emission & Consumptions (only for countries where Euro 5 standard applies)	
<b>Standard</b>	Euro 5
<b>Emission CO<sub>2</sub></b>	120 g/km
<b>Consumptions</b>	5.2 l/100 km



\*Equal to 18,000 miles

Indication of mileage at the first Desmo Service, or rather the first service during which valve clearance is checked and adjusted if necessary.

The Monster is also available for holders of limited driving license in a version with reduced power to 35 kW. Contact your dealer to check availability.

\*\* Please check with your dealer feature availability.

# MONSTER

Ducati Red  
with black wheels



Aviator Grey  
with GP Red wheels



Dark Stealth  
with black wheels

