

MULTISTRADA V4

PIKES PEAK

Dimensions

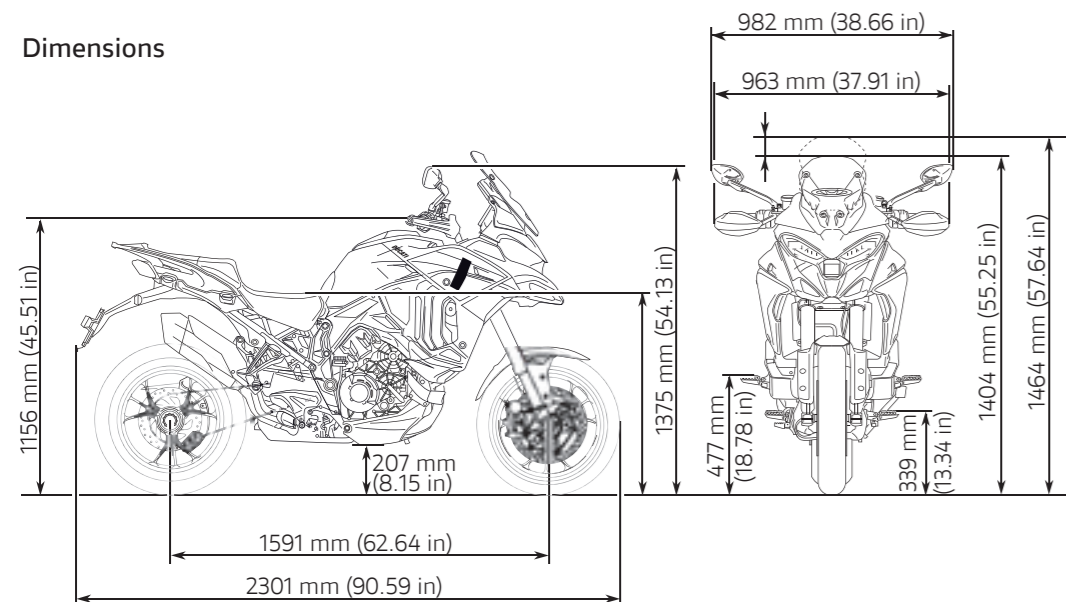

Power and torque

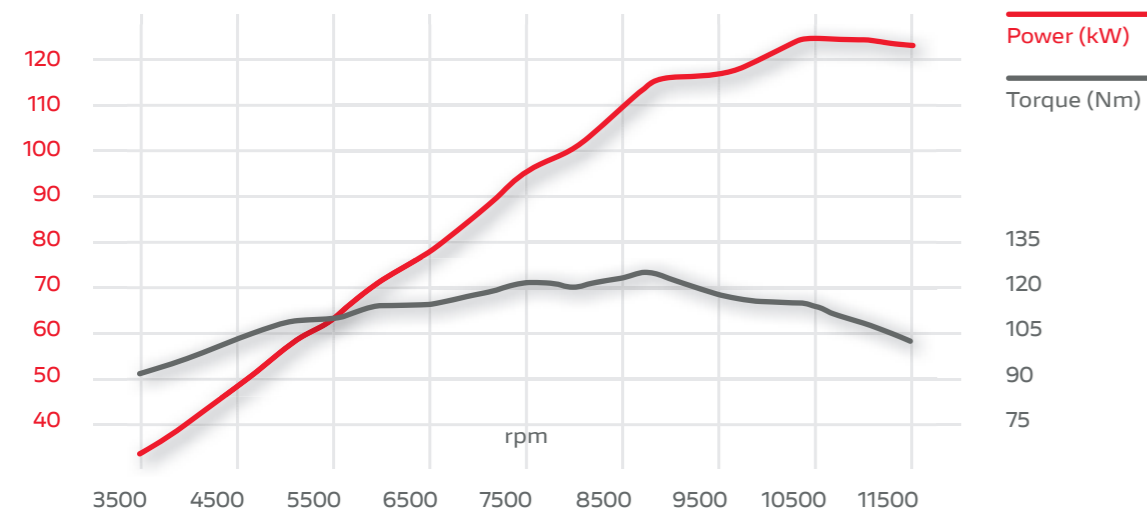

Engine

Engine	V4 Granturismo, V4 - 90°, 4 valves per cylinder, counter-rotating crankshaft, Twin Pulse firing order, liquid cooled
Displacement	1,158 cc (71 cu in)
Bore X Stroke	83 mm x 53.5 mm
Compression ratio	14.0:1
Power	170 hp (125 kW) @ 10,500 rpm
Torque	12.7 kgm (125 Nm, 92 lb ft) @ 8,750 rpm
Fuel injection	Electronic fuel injection system, Ø _{eq} 46 mm elliptical throttle bodies with Ride-by-Wire system
Exhaust	Stainless steel muffler, double catalytic converter and 4 lambda probes

Transmission

Gearbox	6 speed
Primary drive	Straight cut gears, ratio 1.8:1
Ratio	1=40/13, 2=36/16, 3=34/19, 4=31/21, 5=29/23, 6=27/25
Final drive	Chain, front sprocket z16, rear sprocket z42
Clutch	Multiplate wet clutch with hydraulic control, self-servo action on drive, slipper action on over-run

Chassis

Frame	Aluminum monocoque frame
Front suspension	Öhlins Ø 48 mm fully adjustable usd fork with TiN treatment, electronic compression and rebound damping adjustment with Öhlins Smart EC 2.0 event-based mode
Front wheel	Marchesini light alloy forged, 3.5" x 17"
Front tyre	Pirelli Diablo Rosso IV 120/70 ZR17
Rear Suspension	Öhlins TTX36 fully adjustable monoshock, electronic compression and rebound damping adjustment with Öhlins Smart EC 2.0 event-based mode, electronic preload adjustment, aluminium single-sided swingarm
Rear wheel	Marchesini light alloy forged, 6" x 17"
Rear tyre	Pirelli Diablo Rosso IV 190/55 ZR17
Wheel travel (front/rear)	170 mm / 170 mm (6.7 in / 6.7 in)
Front brake	2 x Ø 330 mm semi-floating discs, radially mounted Brembo Stylema monobloc 4-piston 2-pad callipers, radial master cylinder, Cornering ABS
Rear brake	Ø 265 mm disc, Brembo 2-piston floating calliper, Cornering ABS

Instrumentation 6.5" TFT colour display with Ducati Connect and full-map navigation system

Dimensions and Weights

Dry weight	214 kg (472 lb)
Kerb weight*	239 kg (527 lb)
Seat height	Adjustable, 840 mm - 860 mm (33.1 in - 33.9 in)
Wheelbase	1,595 mm (62.8 in)
Rake	25,75°
Trail	120 mm (4.7 in)
Fuel tank capacity	22 l (5.8 US gal)
Number of seats	Dual seat

Safety equipment

Riding Modes, Power Modes, ABS Cornering, Ducati Traction Control, Ducati Wheelie Control, Daytime Running Light, Ducati Cornering Light, Ducati Brake Light, Vehicle Hold Control, Blind Spot Detection

Standard equipment

Öhlins Smart EC 2.0 electronic suspension, Ducati Quick Shift, Adaptive Cruise Control, Hands-free, Backlit handlebar switches, 6.5" TFT colour display with Ducati Connect and full-map navigation system, Full LED headlight, Carbon fiber front mudguard and beak, Type-approved Akrapovic muffler, Two-tone seat

Warranty and Maintenance

Warranty 24 months (48 months*), unlimited mileage

Maintenance 15,000 km (9,000 miles) / 24 months

Valve clearance check 60,000 km (36,000 miles)

Emissions and Consumption**

Standard Euro 5

CO₂ emissions 162 g/km

Consumption 6.5 l/100 km



Equal to 18,000 miles.

Indication of mileage at the first Desmo Service, or rather the first service during which valve clearance is checked and adjusted if necessary.

* Only for countries where 4ever Multistrada warranty applies

** Only for countries where Euro 5 standard applies

MULTISTRADA V4 PIKES PEAK

Pikes Peak livery



1 Low dark-smoked windshield



2 Type-approved Akrapovič exhaust system



3 Electronic Öhlins Smart EC 2.0 suspension