

PANIGALE V4

Dimensions

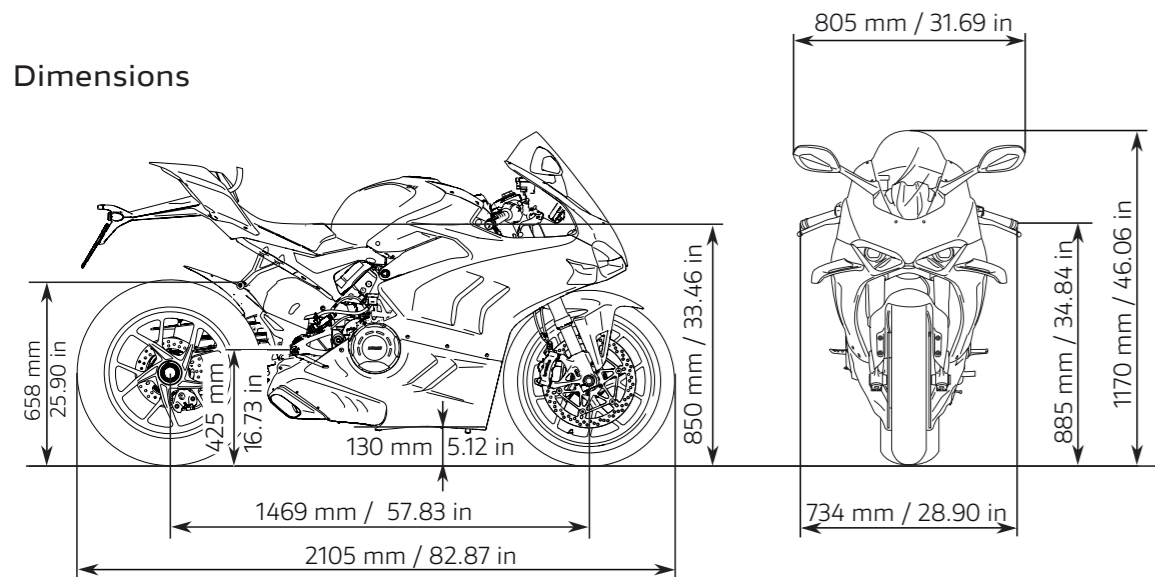

Power and torque

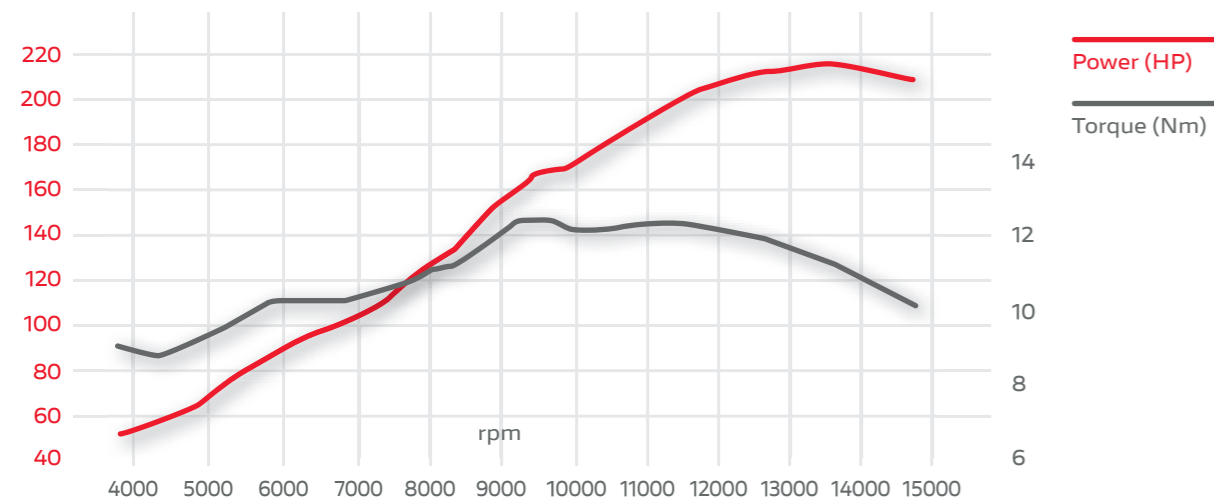

Engine

Engine	Desmosedici Stradale 90° V4, counter-rotating crankshaft, 4 Desmodromic timing, 4 valves per cylinder, liquid-cooled
Displacement	1,103 cc
Bore X stroke	81 x 53.5 mm
Compression ratio	14.0:1
Power	158.5 kW (215.5 hp) @ 13,000 rpm
Torque	123.6 Nm (91.2 lb-ft) @ 9,500 rpm
Fuel injection	Electronic fuel injection system. Twin injectors per cylinder. Full ride-by-wire elliptical throttle bodies. Variable length intake system
Exhaust	4-2-1-2 system, with 2 catalytic converters and 4 lambda probes.

Transmission

Gearbox	6-speed with Ducati Quick Shift (DQS) up/down EVO 2
Primary drive	Straight cut gears; ratio 1.80:1
Ratios	1=36/15 2=34/17 3=33/19 4=32/21 5=30/22 6=27/22
Final drive	Chain 525; Front sprocket 16; Rear sprocket 41
Clutch	Hydraulically controlled slipper and self-servo wet multiplate clutch. Self bleeding master cylinder.

Chassis

Frame	Aluminum alloy "Front Frame" with optimized stiffness
Front suspension	Fully adjustable Showa BPF fork 43 mm chromed inner tubes
Front wheel	5-spoke light alloy, 3.50" x 17"
Front tyre	Pirelli Diablo Supercorsa SP 120/70 ZR17
Rear suspension	Fully adjustable Sachs unit. Aluminum single-sided swingarm
Rear wheel	5-spoke light alloy, 6.00" x 17"
Rear tyre	Pirelli Diablo Supercorsa SP 200/60 ZR17
Wheel travel (front/ rear)	120 mm (4.7 in) - 130 mm (5.1 in)
Front brake	2 x 330 mm semi-floating discs, radially mounted Brembo Monobloc Stylema® (M4.30) 4-piston callipers with Bosch Cornering ABS EVO. Self bleeding master cylinder.
Rear brake	245 mm disc, 2-piston calliper with Bosch Cornering ABS EVO
Instrumentation	Last generation digital unit with 5" TFT colour display

Dimensions and weights

Dry weight	175 kg (386 lb)
Weight in running order	198.5 kg (437.6 lb)
Seat height	850 mm (33.5 in)
Wheelbase	1,469 mm (57.8 in)
Rake	24.5°
Front wheel trail	100 mm (3.94 in)
Fuel tank capacity	17 l - 4.49 gallon (US)
Number of seats	Dual seats

Safety equipment

Riding Modes, Power Modes, Bosch Cornering ABS EVO, Ducati Traction Control (DTC) EVO 3, Ducati Wheelie Control (DWC) EVO, Ducati Slide Control (DSC), Engine Brake Control (EBC) EVO, Auto tyre calibration

Standard equipment

Ducati Power Launch (DPL), Ducati Quick Shift (DQS) up/down EVO 2, Full LED lighting with Daytime Running Light (DRL*), Sachs steering damper, Quick adjustment buttons, Auto-off indicators, Chain guard

Additional equipment

Passenger seat and footpegs kit

Ready for

Ducati Data Analyser+ (DDA+) with GPS module, Ducati Multimedia System (DMS), Anti-theft, Heated grips

Warranty and maintenance

Warranty	24 months unlimited mileage
Maintenance service intervals	12,000 km (7,500 mi) / 12 months

Valve clearance check 24,000 km (15,000 mi)

Emissions and Consumption**

Standard	Euro 5
CO₂ Emissions	175 g/km
Consumption	7,6 l/100km



* equal to 18,000 miles.

Kilometres refer to the first Desmo Service, i.e. when the valve clearance is checked and adjusted if necessary.

The power/torque values indicated were measured on a static testing bench according to type-approval standards and match the data read during the type-approval tests as listed on the vehicle's log book. Max power @ 12,500 rpm for US market only

*Bike specifications and equipment may vary from market to market. Please refer to your local dealer for further information

**Only for countries where Euro 5 standard applies.

PANIGALE V4 S



Panigale V4

Panigale V4 S

Öhlins Smart EC 2.0 system	-	✓
Front suspension	43 mm Showa BPF fork	Öhlins 43 mm NPX25/30 pressurised fork
Rear suspension	Sachs shock absorber	Öhlins TTX36 shock absorber
Steering damper	Sachs	Öhlins
Racing style hand grips	-	✓
Lithium ion battery	-	✓
Wheels	In lightweight alloy	Marchesini in forged aluminium alloy
Dry weight	175 kg (386 lb)	174 kg (384 lb)
Kerb weight	198.5 kg (437.6 lb)	195.5 kg (431 lb)



1 Öhlins 43 mm NPX25/30 pressurised fork



2 Öhlins TTX36 event based rear shock



3 Two-tone seat in technical fabric