

MULTISTRADA V2

Dimensions

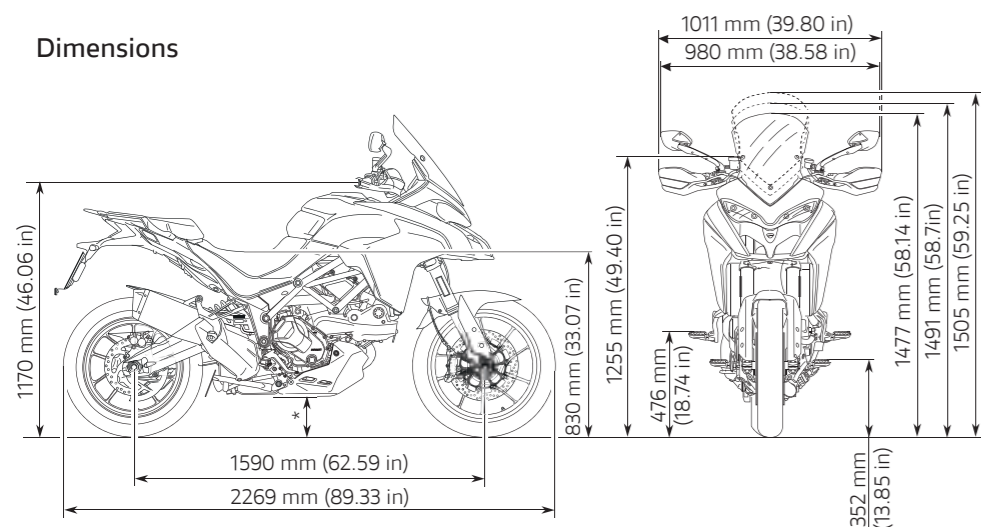

*177 mm (with technopolymer sump guard) 166 mm (with aluminium sump guard)

Power and torque

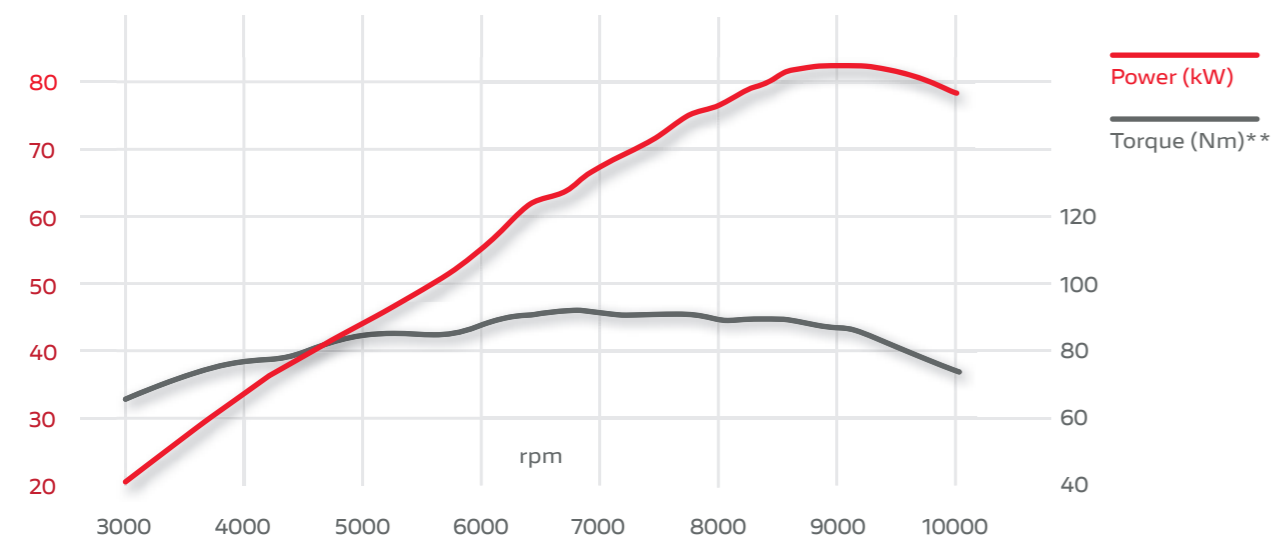

Engine	
Engine	Ducati Testastretta, L-Twin cylinder, Desmodromic valvetrain, 4 valves per cylinder, Liquid cooled
Displacement	937 cc (57.2 cu in)
Bore X Stroke	94 x 67.5 mm
Compression ratio	12.6:1
Power	113 hp (83 kW) @ 9,000 rpm
Torque	96 Nm (9.8 kgm, 71 lb ft) @ 7,750 rpm 94 Nm (9.6 kgm, 69 lb ft) @ 6,750 rpm*
Fuel injection	Electronic fuel injection system, Ø 53 mm throttle bodies with Ride-by-Wire system
Exhaust	Stainless steel single muffler, Catalytic converter and 2 lambda probes
Transmission	
Gearbox	6 speed
Primary drive	Straight cut gears; Ratio 1.84:1
Ratio	1=37/15, 2=30/17, 3=28/20, 4=26/22, 5=24/23, 6=23/24
Final drive	Chain; Front sprocket 15; Rear sprocket 43
Clutch	Slipper and self-servo wet multiplate clutch with hydraulic control

Chassis	
Frame	Tubular steel trellis frame
Front suspension	Ø 48 mm fully adjustable usd fork
Front wheel	Light alloy casted 3.0" x 19"
Front tyre	Pirelli Scorpion Trail II 120/70 ZR 19
Rear Suspension	Fully adjustable monoshock, Remote spring preload adjustment, Aluminium double-sided swingarm
Rear wheel	Light alloy casted 4.5" x 17"
Rear tyre	Pirelli Scorpion Trail II 170/60 ZR 17
Wheel travel (front/rear)	170 mm / 170 mm (6.7 in / 6.7 in)
Front brake	2 x Ø 320 mm aluminum flange semi-floating discs, Radially mounted Brembo monobloc 4-piston 2-pad callipers, Radial Master Cylinder, Cornering ABS
Rear brake	Ø 265 mm disc, 2-piston Brembo floating calliper, Cornering ABS
Instrumentation	LCD Display

Dimensions and Weights	
Dry weight	199 kg (439 lb)
Kerb weight*	222 kg (489 lb)
Seat height	830 mm (32.7 in)
Wheelbase	1,594 mm (62.8 in)
Rake	25°
Trail	106 mm (4.2 in)
Fuel tank capacity	20 l (5.3 US Gal)
Number of seats	Dual seat
Safety equipment	
Riding Modes, Power Modes, Ducati Safety Pack (Cornering ABS, Ducati Traction Control), Ducati Brake Light, Vehicle Hold Control	
Standard equipment	
Self cancelling turn indicators	
Ready for	
Ducati Quick Shift up/down, Ducati Multimedia System, Antitheft system	
Warranty and Maintenance	
Warranty	24/48** months, Unlimited mileage

Maintenance	15,000 km (9,000 miles) / 24 months
Valve clearance check	30,000 km (18,000 miles)
Emissions and Consumption*	
Standard	Euro 5
CO₂ emissions	137 g/km
Consumption	5,9 l/100km



Equal to 18,000 miles.

Indication of mileage at the first Desmo Service, or rather the first service during which valve clearance is checked and adjusted if necessary.

The Multistrada V2 is also available for holders of limited driving license in a version with reduced power to 35 kW. Contact your dealer to check availability.

* Only for countries where Euro 5 standard applies

** Only for countries where 4ever Multistrada warranty applies