

HYPERMOTARD 950

Dimensions

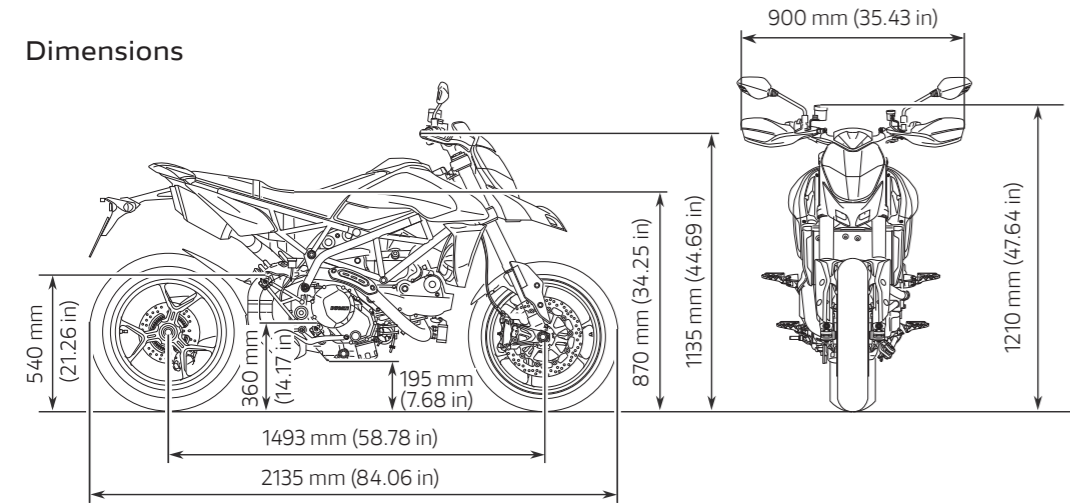

Power and torque

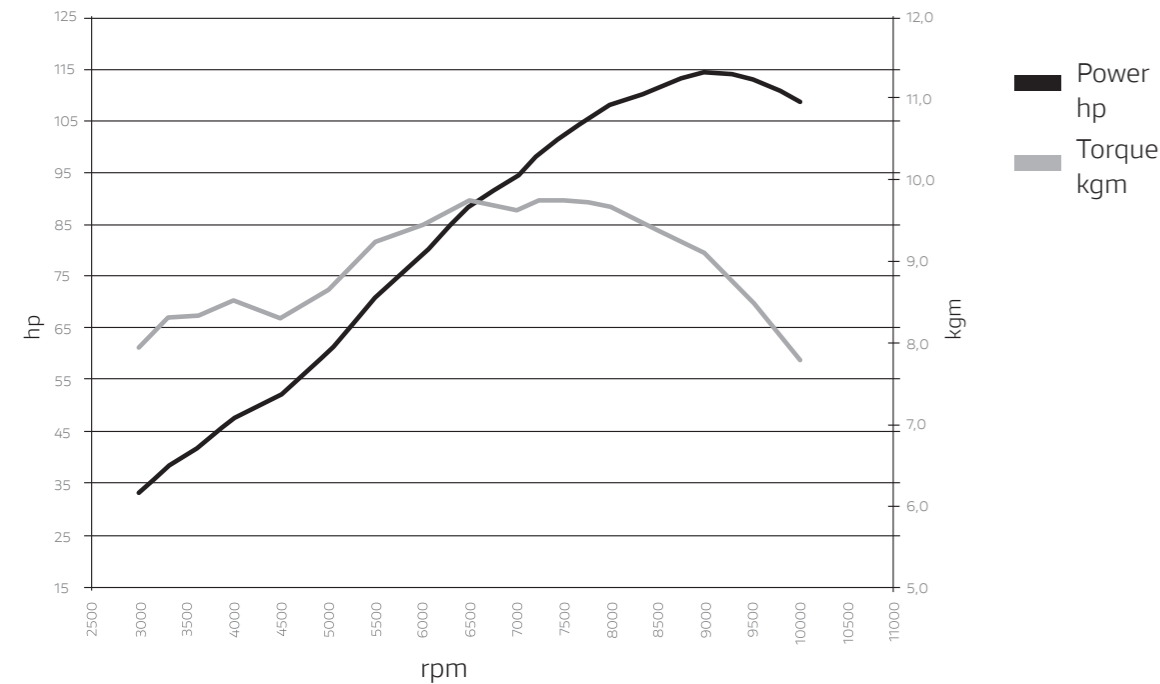

Engine	
Engine	Testastretta 11°, L-Twin cylinder, 4 valve per cylinder, Desmodromic, liquid cooled, magnesium head covers, hydraulic clutch command
Displacement	937 cc
Bore X stroke	94 x 67,5 mm (3,70 x 2,66 in)
Compression ratio	13,3:1
Maximum power	114 hp (84 kW) @ 9.000 rpm
Maximum torque	71 lb-ft (96 Nm) @ 7.250 rpm
Fuel injection	Electronic fuel injection system, Ø 53 mm throttle bodies with full Ride by Wire system
Exhaust	Double under-tail aluminum muffler; catalytic converter and two lambda probes.
Transmission	
Gearbox	6 speed
Primary drive	Straight cut gears; Ratio 1.85:1
Ratio	1=37/15 2=30/17 3=28/20 4=26/22 5=24/23 6=23/24
Final drive	Chain; Front sprocket 15; Rear sprocket 43
Clutch	Slipper and self-servo wet multiplate clutch, hydraulic control

Chassis	
Frame	Tubular steel Trellis frame
Front suspension	Marzocchi aluminum fully adjustable, upside-down Ø 45 mm
Front wheel	Y shaped 3-spoke light alloy 3.5" x 17"
Front tyre	Pirelli Diablo Rosso III, 120/70 ZR17
Rear suspension	Progressive linkage with adjustable spring preload and rebound damping Sachs monoshock. Aluminium single-sided swingarm
Rear wheel	Y shaped 3-spoke light alloy 5.5" x 17"
Rear tyre	Pirelli Diablo Rosso III, 180/55 ZR17
Wheel travel (front/rear)	170 mm (6.7 in) - 150 mm (5.9 in)
Front brake	2 x Ø 320 mm semi-floating aluminum flange discs, radially mounted Monobloc Brembo callipers, 4-piston 2-pad, radial pump with adjustable lever, with ABS Bosch Cornering
Rear brake	Ø 245 mm disc, 2-piston calliper, with ABS Bosch Cornering
Instrumentation	Full-TFT color display

Dimensions and Weights	
Dry weight	178 kg (392 lb)
Kerb weight	200 kg (440 lb)
Seat height	870 mm (34.2 in)
Wheelbase	1493 mm (58,8 in)
Rake	25°
Front wheel trail	104 mm (4.1 in)
Fuel tank capacity	14.5 l (3.8 US gal)
Number of seats	2

Standard Equipment

Riding Modes, ABS Bosch Cornering, Ducati Slide by Brake, Ducati Traction Control (DTC) EVO, Ducati Wheelie Control (DWC) EVO, Power Modes, Ride-by-Wire, Day Time Running Light (DRL), Tapered aluminum handlebars, Removable passenger footpegs, USB power socket, Ready for: Anti-theft system, Ducati Quick Shift (DQS) up/down EVO, Heated grips, Ducati Multimedia System (DMS).

Warranty

24 months unlimited mileage

Maintenance

Maintenance service intervals 15,000 km (9,000 mi)/12 months

Maintenance	
Valve clearance adjustment	30,000 km (18,000 mi)
Emissions & Consumption*	
Standard	Euro 5
CO₂ Emissions	123 g/km
Consumption	5,3 l/100 km



Equal to 18,000 miles

Kilometers refer to the first Desmo Service, i.e. when the valve clearance is checked and adjusted if necessary.

* Only for countries where Euro 5 standard applies.

A 35 kW restricted power version of the Hypermotard 950 is available for restricted license holders. Please contact your dealer for information on availability.