

DIAVEL 1260

Dimensions

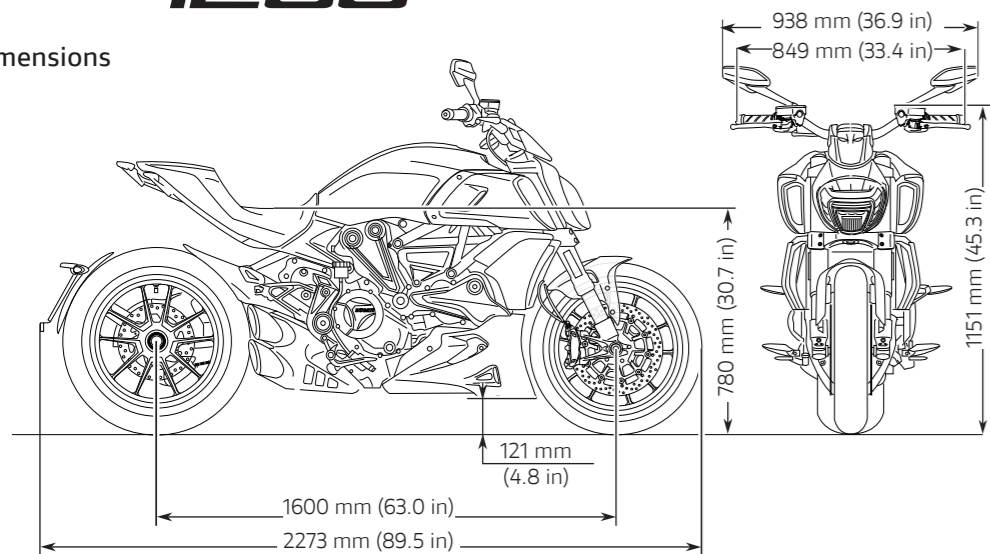

Power and torque*

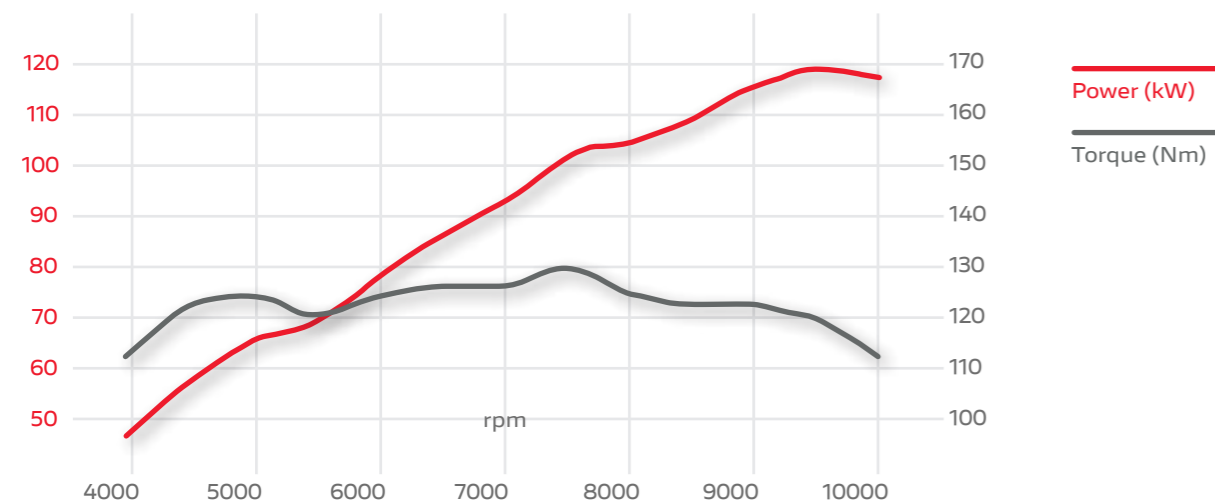

Engine	
Engine	Ducati Testastretta DVT 1262, L-Twin cylinder, 4 valves per cylinder, Dual Spark, Liquid cooled, Desmodromic Variable Timing
Displacement	1,262 cc (77.0 cu in)
Bore X stroke	106 x 71.5 mm
Compression ratio	13.0 : 1
Maximum power	162 hp (119 kW) @ 9,500 rpm* 157 hp (116 kW) @ 9,250 rpm** 159 hp (117 kW) @ 9,500 rpm ***
Maximum torque	13.2 kgm (129 Nm, 95 lb ft) @ 7,500 rpm
Fuel injection	Electronic fuel injection system, Øeq 56 mm elliptical throttle bodies with Ride-by-Wire system
Exhaust	Stainless steel silencer, catalytic converter and two lambda probes
Transmission	
Gearbox	6 speed
Primary drive	Straight cut gears, Ratio 1.84:1
Ratio	1=37/15, 2=30/17, 3=27/20, 4=24/22, 5=23/24, 6=22/25
Final drive	Chain, Front sprocket Z15, Rear sprocket Z43
Clutch	Slipper and self-servo wet multiplate clutch with hydraulic control

Chassis	
Frame	Tubular steel trellis frame
Front suspension	Ø 50 mm adjustable usd fork
Front wheel	Light alloy cast 3.5"x17"
Front tyre	Pirelli Diablo Rosso III 120/70 ZR17
Rear suspension	Monoshock, preload and rebound adjustable, Aluminium casted single-sided swingarmw
Rear wheel	Light alloy cast 8.0"x17"
Rear tyre	Pirelli Diablo Rosso III 240/45 ZR17
Wheel travel (front/rear)	120 mm / 130 mm (4.7 in / 5.1 in)
Front brake	2 x Ø 320 mm semi-floating discs, Radially mounted Brembo monobloc 4-piston M4.32 callipers, PR18/19 radial master cylinder, Cornering ABS Evo
Rear brake	Ø 265 mm disc, 2-piston Brembo floating calliper, Cornering ABS Evo
Instrumentation	3.5" TFT colour display and dedicated warning light display

Dimensions and Weights	
Dry weight	223 kg (492 lb)
Kerb weight	249 kg (549 lb)
Seat height	780 mm (30.7 in)
Wheelbase	1,600 mm (63.0 in)
Rake	27°
Front wheel wtrail	120 mm (4.7 in)
Fuel tank capacity	17 l (4.5 US gal) 16 l (4.2 US gal)**
Number of seats	2

Standard Equipment

Riding Modes, Power Modes, Ducati Safety Pack (Cornering ABS Evo, Ducati Traction Control Evo DTC), Ducati Wheelie Control Evo (DWC), Cruise control, Ducati Power Launch Evo (DPL), Hands-Free, Backlit handlebar switches, 3.5" TFT colour display, Full LED lighting system, Self cancelling turn indicators. Ready for : Ducati Quick Shift up/down Evo (DQS), Ducati Multimedia System (DMS), Antitheft system

Warranty

24 months, Unlimited mileage

Maintenance	
Maintenance service intervals	15,000 km (9,000 miles) / 12 months
Valve clearance check	30,000 km (18,000 miles)
Emissions & Consumption*	
Standard	Euro 5
CO₂ Emissions	129 g/km
Consumption	5,5 l/100 km



Equal to 18,000 miles.

* Only for countries where Euro 5 standard applies.
** Only for US, Canada and Mexico.
*** Other countries.