

Dimensions

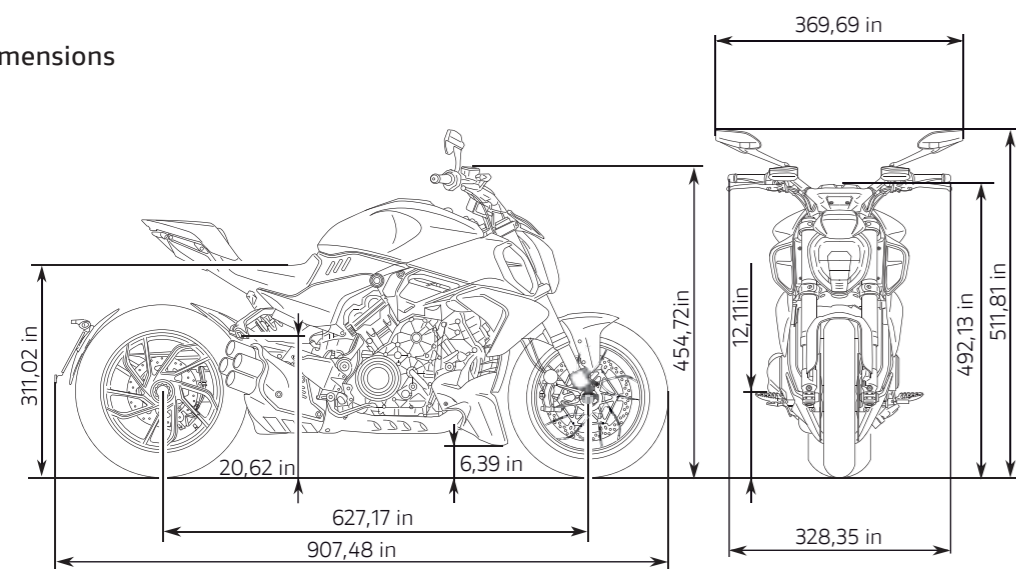

Power and torque

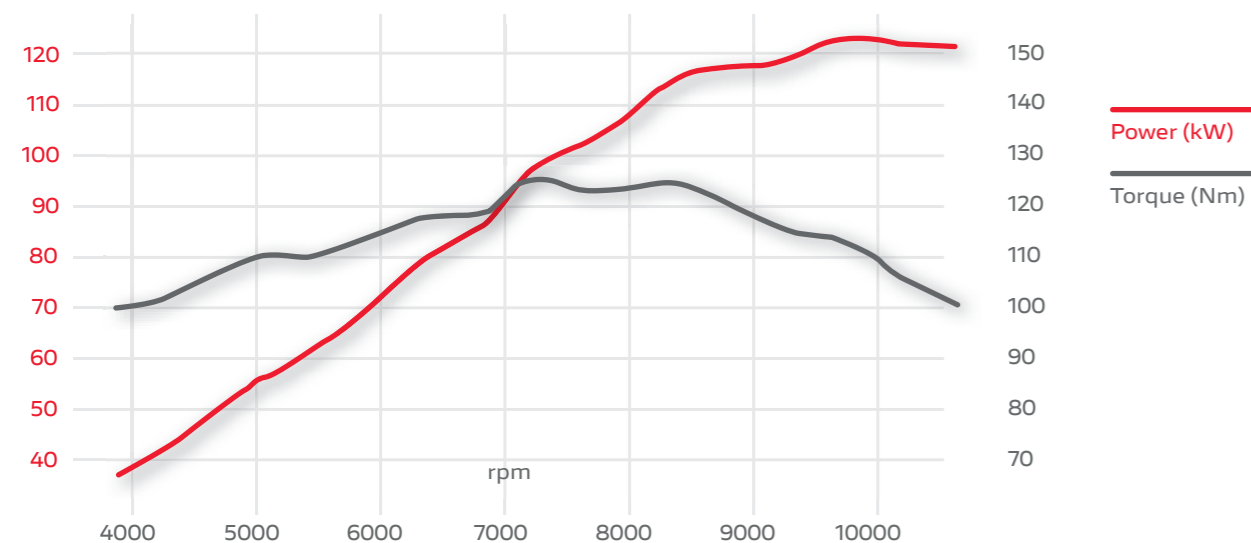

Engine

Engine	V4 Granturismo, V4 - 90°, 4 valves per cylinder, counter-rotating crankshaft, Twin Pulse firing order, liquid cooled
Displacement	1,158 cc (71 cu in)
Bore X stroke	83 mm x 53.5 mm
Compression ratio	14.0:1
Maximum power	168 hp (124 kW) @ 10,750 rpm
Maximum torque	12.8 kgm (126 Nm, 93 lb ft) @ 7,500 rpm
Fuel injection	Electronic fuel injection system, Øeq 46 mm elliptical throttle bodies with Ride-by-Wire system
Exhaust	Stainless steel exhaust muffler with 4 exit pipes, 2 catalytic converters and 4 lambda probes

Transmission

Gearbox	6 speed with Ducati Quick Shift up/down
Primary drive	Ratio 1.80:1
Ratio	1=40/13, 2=36/16, 3=34/19, 4=31/21, 5=29/23, 6=27/25
Final drive	Chain, front sprocket Z16, rear sprocket Z43
Clutch	Hydraulically controlled slipper and self-servo wet multiplate clutch

Chassis

Frame	Aluminum monocoque frame
Front suspension	Ø 50 mm fully adjustable usd fork
Front wheel	Light alloy cast, 3.5" x 17"
Front tyre	Pirelli Diablo Rosso III, 120/70 ZR17
Rear suspension	Fully adjustable monoshock, aluminium single-sided swingarm
Rear wheel	Light alloy cast 8.0"x17"
Rear tyre	Pirelli Diablo Rosso III, 240/45 ZR17
Wheel travel (front/rear)	120 mm / 145 mm (4.7 in / 5.7 in)
Front brake	2 x Ø 330 mm semi-floating discs, radially mounted Brembo Stylema monobloc 4-piston callipers, radial master cylinder PR16/19, Cornering ABS
Rear brake	Ø 265 mm disc, Brembo 2-piston floating calliper, Cornering ABS
Instrumentation	5" TFT colour display

Dimensions and Weights

Dry weight	211 kg (465 lb)
Kerb weight	236 kg (520 lb)
Seat height	790 mm (31.1 in)
Wheelbase	1,593 mm (62.7 in)
Rake	26°
Front wheel wtrail	112 mm (4.4 in)
Fuel tank capacity	20 l (5.3 US gal)
Number of seats	2

Safety Equipment

Riding Modes, Power Modes, Cornering ABS, Ducati Traction Control, Ducati Wheelie Control, Daytime Running Light*, Ducati Brake Light

Standard Equipment

Ducati Quick Shift, Ducati Power Launch, Cruise control, Hands-Free, 5" TFT colour display, Ducati Multimedia System, Backlit handlebar switches, Full-LED lighting system, Dynamic turn indicators*

Ready for

Turn-by-Turn navigation system

Warranty and Maintenance

Warranty	24 months, unlimited mileage
Maintenance service intervals	15,000 km (9,000 miles) / 24 months
Valve clearance check	60,000 km (36,000 miles)

Emissions & Consumption**

Standard	Euro 5
CO₂ Emissions	154 g/km
Consumption	6.4 l/100 km



Equal to 36,000 miles.
 Indication of the mileage during which it is carried out the control and eventual adjustment of the valve clearance.
 *Please check with your dealer product availability
 **Only for countries where Euro 5 standard applies

DIAVEL V4

Ducati Red



Thrilling Black

